



hosseven
ISI VE YALITIM SAN. TİC. AŞ.



HOSSEVEN AIR PELLET STOVE

USER MANUAL

P10



hosseven
ISI VE YALITIM SAN. TİC. AŞ.



"P10" 10 kW air pellet stove

We would like to thank you for choosing one of our stoves. Our product is a great heating solution developed from the most advanced technology with top quality machining and modern design, aimed at making you enjoy the fantastic sensation that the heat of a flame gives, in complete safety.

Hoşseven Isı & Yalıtım A.Ş

WARNINGS.....	3
SAFETY.....	3
ROUTINE MAINTENANCE.....	5
REFERENCE STANDARTS.....	5
TERMS AND DEFINITIONS.....	5
DESCRIPTION OF THE STOVE.....	7
INSTALLATIO.....	8
FUMES EXHAUST SYSTEM.....	10
SMOKE DUCT.....	11
COMBUSTION PRODUCTS OUTLET QUOTA.....	13
FUMES EXHAUST SYSTEM PRODUCT REQUIREMENTS.....	14
TECHNICAL INSTALLATION DOCUMENTATION.....	15
PELLETS AND FEEDING.....	16
USER INTERFACE KEYBORD REMOTE CONTROL.....	17
OPERATING MODE.....	18
MENU.....	21
ELECTRICAL LAYOUT.....	28
MAINTENANCE.....	28
ROUTINE MAINTENANCE.....	30
ALARMS.....	31
COMBUSTION PHASE OF FLAMES SIMULATING.....	33

WARNINGS

This instructions manual is an integral part of the product: make sure that it always accompanies the appliance, even if transferred to another owner or user, or if transferred to another place. If it is damaged or lost, request another copy from the area technician. This product is intended for the use for which it has been expressly designed. The manufacturer is exempt from any liability, contractual and extracontractual, for injury/damage caused to persons/animals and objects, due to installation, adjustment and maintenance errors and improper use.

Installation must be performed by qualified staff, which assumes complete responsibility for the definitive installation and consequent good functioning of the product installed. One must also bear in mind all laws and national, regional, provincial and town council standards present in the country in which the appliance has been installed, as well as the instructions contained in this manual.

The manufacturer cannot be held responsible for the failure to comply with such precautions. After removing the packaging, ensure that the content is intact and complete. Otherwise, contact the dealer where the appliance was purchased. All electric components that make up product must be replaced with original spare parts exclusively by an authorized after-sales center, thus guaranteeing correct functioning.

SAFETY



The generator must not be used by persons (including children) with reduced physical, sensory and mental capacities or who are unskilled persons, unless they are supervised and trained regarding use of the appliance by a person responsible for their safety.



Children must be checked to ensure that they do not play with the appliance.



Do not touch the generator when you are barefoot or when parts of the body are wet or damp.



The safety and adjustment devices must not be modified without the authorization or indications of the manufacturer.



Do not pull, disconnect, twist electric cables leaving the stove, even if disconnected from the electric power supply mains.



It is advised to position the power supply cable so that it does not come into contact with hot parts of the appliance.



The power supply plug must be accessible after installation.



Do not close or reduce the dimensions of the airing vents in the place of installation. The airing vents are essential for correct combustion.



Do not leave the packaging elements within reach of children or unassisted disables persons.



The hearth door must always be closed during normal functioning of the product.



When the appliance is functioning and hot to the touch, especially all external surfaces, attention must be paid.



Check for the presence of any obstructions before switching the appliance on following a prolonged period of inactivity.



The generator has been designed to function in any climatic condition (even critical). In particularly adverse conditions (strong wind, freezing) safety systems may intervene to switch the generator off. If this occurs, contact the technical after-sales service and always disable the safety systems.



In the event the flue catches fire, use suitable systems for suffocating the flames or request help from the fire brigade.



This appliance must not be used to burn waste.



Do not use any flammable liquids for ignition.



During the filling phase do not put the bag of pellets into contact with the product.



The enamel products are top quality artisan products. These features highlight their valuable nature. Due to their different dilation coefficient, they produce crackling, which demonstrates their effective authenticity. To clean the majolica's, it is recommended to use a soft, dry cloth. If a detergent or liquid is used, the latter could penetrate inside the crackles, highlighting them.

ROUTINE MAINTENANCE

Routine maintenance means interventions aimed at reducing degradation due to normal use, as well as dealing with accidental events entailing the need of first interventions, which however do not modify the structure of the system upon which one is intervening or its intended use according to the requirements laid down by the technical standards in force and by the manufacturer's use and maintenance manual.

REFERENCE STANDARDS

The installation must be in compliance with:

Hoşseven products are manufactured according to the directives:

- 89/106 EEC Construction materials
- 2014/35 EU Low voltage
- 2011/65 EU RoHS
- 2014/30 EU Electro-magnetic compatibility
- 2009/125 EC Ecodesign

And according to the standards

- EN 14785 EU 2015/1186
- EN 60335-1 EN 60335-2-102 EN 50581
- EN 55014-1 EN 61000-3-2 EN 61000-3-3
- EN 55014-2 EN 62233

NATIONAL, REGIONAL, PROVINCIAL AND TOWN COUNCIL REGULATIONS

One must also bear in mind all laws and national, regional provincial and town council standards present in the country in which the appliance has been installed.

TERMS AND DEFINITIONS

Aeration: Air renewal is required both for the disposal of the combustion products, and to prevent mixtures with a hazardous content of non-combusted gases.

Closed hearth appliance: Appliance designed for operation with closed combustion chamber.

Forced draught appliance: Appliance with ventilation in the fumes circuit and combustion with fumes flow at a positive pressure with respect to the environment.

Chimney: Structure consisting in one or several walls containing one or several outflow airways. The purpose of this predominantly vertical element is to expel the combustion products at a convenient height from the ground.

Smoke duct: Component or components that connect the outlet of the heat generator to the chimney.

Chimney cap: Device that placed on the chimney outlet allows the dispersion of the combustion products even in presence of adverse weather conditions.

Condensation: Liquid products which form when the fumes temperature is lower or equal to the water dew point.

Ducting pipe: Pipe made up of one or several predominantly vertical elements, specifically suitable for collecting and expelling the fumes, as well as to withstand the relative components and any condensate over time, suitable to be installed in a chimney, existing or new technical compartment, even in new buildings.

Sealed installation: Installation of an appliance with sealed operation, so that all the air required for combustion is taken from outside.

Maintenance: Set of procedures required to ensure and maintain safety and functionality over time and maintain the efficiency of the system within the prescribed parameters.

Chimney system: Chimney installed using a combination of compatible components, manufactured or specified by a sole manufacturer whose product liability covers the entire chimney.

Fumes exhaust system: Flue gas exhaust system, independent from the appliance made up of a smoke duct, chimney or individual flue and chimney cap.

Radiation area: Area immediately in front of the hearth in which the radiant heat caused by combustion is diffused.

Reflux area: Area beyond the extrados of the roof in which overpressure or depressions occur, which may affect the proper discharge of the combustion products.

DESCRIPTION OF THE STOVE

		P10
Height	mm	900
Width	mm	423
Depth	mm	507
Weight (net)	kg	66
Diameter of flue gas pipe	mm	80
Heating output reduced-nominal	kW	3,5 – 10
Max heating volume	m ³	270
Tank capacity	kg	12,6
Consumption min-max	kg/h	0,86 – 2,2
Flue gas temperature min-max	°C	88 – 150
Efficiency at reduced-nominal P.	%	94,70 – 91,20
CO at 13% O ₂ min-max	%	0,01 – 0,02
CO at 13% O ₂ min-max	mg/Nm ³	99,24 – 189,58
Dust in the flue gas at 13 % O ₂	mg/Nm ³	12,18 – 14,54
NO _x at 13 % O ₂ min-max	mg/Nm ³	109,35 – 119,24
OGC	mg/Nm ³	2,5 – 4,94
Draught min	Pa	11,10
Supply	V-Hz	230 Vac 50 Hz

The data shown here is provided as a guideline and is not binding, and may change based on what type and quality of wood is used.

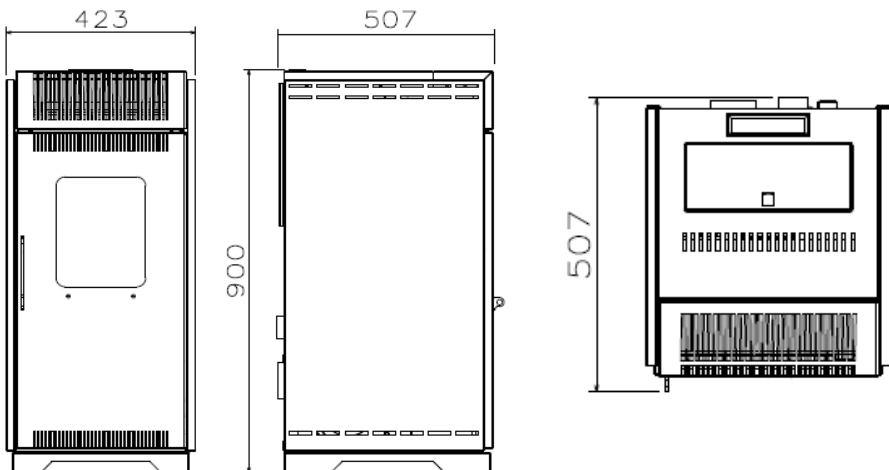

INSTALLATION

Installation not allowed

Installation in premises with fire hazards is forbidden. Installation in residential premises (except for sealed operation appliances)

- In which there are liquid fuel-operated appliances with continuous or intermittent operation, which draw the combustion air in the room in which they installed, or
- In which there are type B gas appliances intended for room heating, with or without production of domestic hot water and in adjacent and adjoining premises.

Installations in bathrooms, bedrooms and studio flats

Installation in bathrooms, bedrooms and studio flats is only allowed for sealed or closed hearth appliances with ducted combustion air taken from the outside.

Installation premises requirements

The support surfaces and/or points must have a suitable load-bearing capacity to support the weight of the appliance, of the accessories and coatings.

The adjacent, side and rear walls and the supporting surface must be made of non-combustible material. Installation near combustible materials or those sensitive to heat is permitted as long as there is a suitable safety distance, which for pellet stoves is equal to:

References	Flammable Objects	Inflammable objects
A (side)	500 mm	200 mm
B (front)	1000 mm	500 mm
C (behind)	500 mm	200 mm

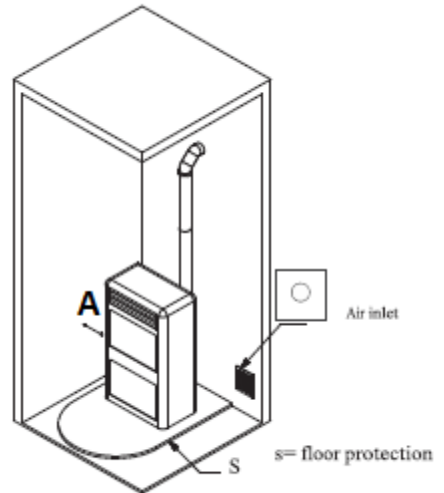
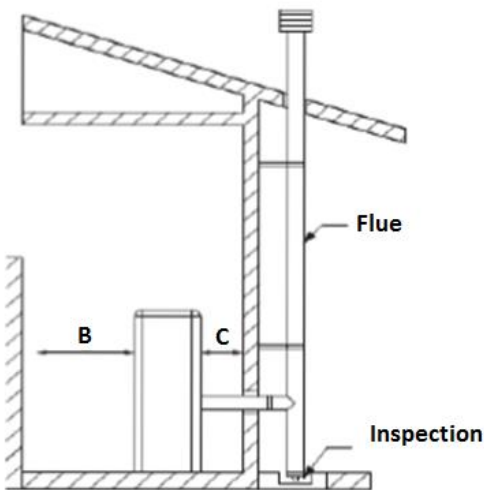

In any case the temperature of the adjacent combustible materials must not reach a temperature equal to or greater than the room temperature increased by 65°C.

The minimum volume of the premises in which to install the appliance must be greater than 15 m³.

VENTILATION AND AERATION OF THE INSTALLATION PREMISES

Ventilation is deemed sufficient when the room is equipped with air inlets according to the table; air inlet see at below

Appliance categories	Reference standard	Percentage of the net opening section with respect to the appliance furnace outlet section	Minimum net opening Value of the ventilation duct
Pellet stoves	EN 14785	-	80 cm ²

In any case ventilation is deemed sufficient when the pressure difference between the external and internal environment is equal to or less than 4 Pa.

In the presence of type B gas appliances with intermittent operation not intended for heating, they must have their own aeration and/or ventilation opening. The air inlets must meet the following requirements.

- They must be protected with grids, metal mesh, etc., but without reducing the net useful section;
- They must be made so as to make the maintenance operations possible;
- Positioned so that they cannot be obstructed;

The flow of clean, uncontaminated air can also be obtained from a room adjacent to that of installation (indirect aeration and ventilation), as long as the flow takes place freely through permanent openings communicating with the outside.

The adjacent room cannot be used as a garage, warehouse of combustible material or for any other activity with a fire hazard, bathroom, bedroom or common room of the building.

FUMES EXHAUST SYSTEM GENERAL REQUIREMENTS

The heat generator works in a vacuum and has an output fan for fume extraction. Each appliance must be connected to a suitable fumes exhaust system and ensure adequate dispersion of the combustion products into the atmosphere. The combustion products must be discharged above the roof. Direct discharge from the wall or towards closed spaces is forbidden, even with clean skies.

In particular, it is forbidden to use flexible and extendible metal pipes. The chimney should only receive the exhaust of the smoke duct connected to the appliance; collective flues or conveying exhaust from hoods above cooking appliances of any kind, or exhausts from other generators into the chimney itself or smoke duct are not allowed.

The smoke duct and the chimney must be connected with a continuity solution, in order to prevent the chimney from resting on the appliance.

It is forbidden to have other air supply channels and pipes for plant engineering transit inside the fumes exhaust systems, especially if over-sized.

The components of the fumes exhaust system must be chosen in relation to the type of appliance to be installed in compliance with:

- Metal chimneys should be in accordance with the relevant standard mentioned on the fifth page
- Temperature class;
- Pressure class (fumes seal) at least equal to the seal required for the appliance;

- Moisture resistance (resistance to condensation)
- Class or level of corrosion and specification of the materials constituting the inner wall in contact with the fumes.
 - Soot fire resistance class;
 - Minimum distance from combustible materials
 - Where due to high efficiency a pellet stove has fumes at a temperature off less than 160°C + ambient (see technical data)

The installer of the fumes exhaust system, once the installation is complete and the relevant checks and inspections have been made, must fix the chimney plaque supplied by the manufacturer with the product in a visible manner, near the fireplace, and which must be completed with the following information:

- Normal diameter;
- Distance from combustible materials, indicated in millimeters, followed by the arrow and flame symbol;
- Installer data and date of installation.

Every time one must cross combustible materials, the following indications must be complied with:

SMOKE DUCT

General requirements

The smoke ducts must be installed in compliance with the following general requirements:

- Be equipped with at least one sealed outlet for eventual fumes sampling;
- They must be insulated if they cross through rooms that are not to be heated or outside the building;
- They must not cross rooms in which the installation of combustion appliances is forbidden, nor in other premises compartmentalized against fire or with a fire hazard, nor in rooms and/or areas that cannot be inspected;
- They must be installed so as to allow normal thermal expansion;
- They must be fitted to the opening of the chimney without protruding inwards;
- The use of flexible metal pipes to connect the appliance to the chimney is not allowed;

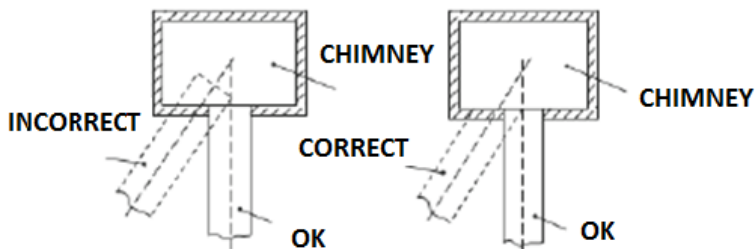

Counter-slope sections are not allowed;

- The smoke ducts must have along their entire length, a diameter that is no less than that of the attachment of the appliance exhaust pipe; any section changes are allowed only on the inlet to the chimney;
- They must be installed so as to limit the formation of condensation and prevent their release from the joints;
- They must be positioned at a distance no less than that indicated in the product specifications from combustible materials;
- The smoke channel/duct must allow to collect the soot and to be cleaned using a swab and inspected after being disassembled, or through inspection openings when not accessible from inside the appliance.

ADDITIONAL REQUIREMENTS FOR APPLIANCES FITTED WITH AN ELECTRIC FAN FOR FUMES EXPULSION

For the heat generator appliances equipped with electric fan for expelling fumes, the instructions below must be followed:

- The horizontal sections must have a minimum upward slope of 3%
- The length of the horizontal section must be minimal and, in any case, no longer than 3 meters
- The number of direction changes including the one due to the use of the “T” element must not be more than 4.

Chimney

In addition to the general requirements, the chimneys for releasing combustion products into the atmosphere must:

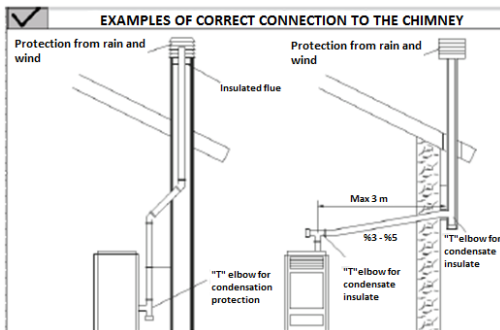
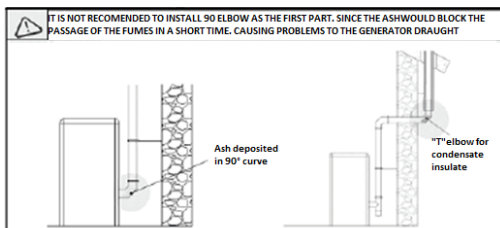

- Operate under negative pressure (operation under positive pressure is not allowed)
- Have a preferably circular internal section; square or rectangular sections must have rounded corners with a radius of no less than 20 mm (hydraulically equivalent sections may be used, as long as the ratio between the longer side and the shorter side of the rectangle, which circumscribes the section, is in any case no greater than 1.5);
- Be designed for fumes be designed for fumes expulsion;
- Be predominantly vertical and have no narrowing along their entire length;
- Have no more than two direction

changes with a slope angle no greater than 45°;

- Be fitted with, in the event of operating in damp conditions, a device for reflux drainage (condensation, rainwater);

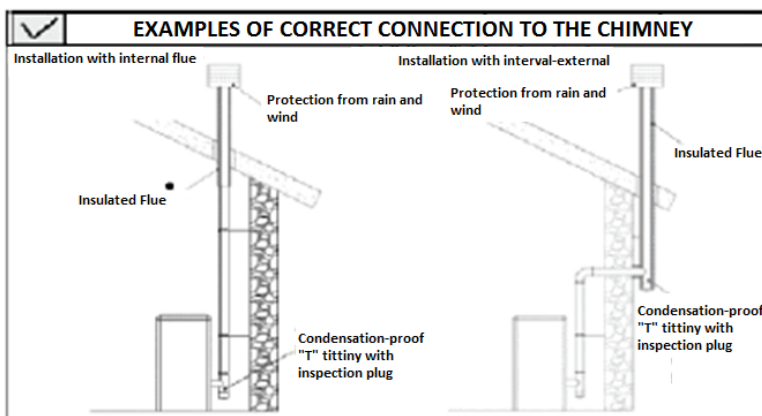

COMBUSTION PRODUCTS OUTLET QUOTA

The outlet quota is determined by measuring the minimum height between the roof covering and the lower point of the fumes expulsion section into the atmosphere; this quota must be outside the reflux area and at an adequate distance from obstacles which hinder

or make the expulsion of the combustion products difficult or from openings or accessible areas.

Reflux area

The outlet quota must be outside the reflux area calculated according to indications below. Near the ridge one considers the lowest between the two.

Buffer area for outlet quota

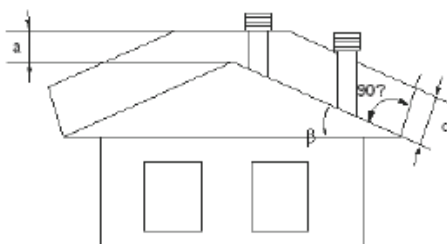

**Clear area for outlet quota
above the roof slope ($\beta > 10^\circ$)**

REFERENCE	DESCRIPTION	CLEAR AREA (mm)
c	Distance measured at 90° from the roof surface	1300
a	Height above the ridge of the roof	500

The outlet of chimney/ducted system must not be near obstacles that may create turbulence areas and/or prevent proper expulsion of combustion products and maintenance operations to be carried out on the roof.

Verify the presence of other chimney caps or skylights and dormers.

FUMES EXHAUST SYSTEM PRODUCT REQUIREMENTS

Temperature class

In the event of a pellet appliance, temperature classes below T200 are not allowed.

Soot fire resistance class

The fumes exhaust system interlocked with appliances supplied by solid fuels require soot fire resistance, and the specification must be indicated by the letter G followed by the distance from combustible materials in millimeters (XX) (in compliance with 1443:2006)

In the event of pellet appliances, the fumes exhaust systems must be airtight; if double designation elements are used (G and o, with or without seal elastomer) for connecting the appliance to the chimney, one must comply with the minimum distance XX millimeters , indicated for designation G; in the event of fire due to soot, one must comply with the restoration of the initial conditions (by replacing the gaskets and damaged items and cleaning those remaining in use).

Ignition tests

Operation of the appliance must be verified with an ignition test, i.e.:

- For mechanical feed appliances, one must complete the ignition test, verify proper operation for at least the next 15 minutes and adjust the switch-off;

TECHNICAL INSTALLATION DOCUMENTATION

When installation is complete, the installer must provide the owner or person acting for him, according to the legislation in force, with the declaration of conformity, supplied with:

1. The use and maintenance manual of the appliance and of the system components (such as for example, the smoke ducts, chimney, etc.);
2. Photocopy or photograph of the chimney plaque,
3. System booklet (where applicable)

The installer must ask to be issued with a receipt stating that the documentation has been provided, and must keep it with a copy of the technical documentation relating to the installation.

Installation performed by several parties

If the individual installation steps are carried out by different parties, each must document the work carried out for the customer and the for the operator working on the next step.

PELLETS AND FEEDING

Pellets are made by applying high pressure to sawdust, or wood waste products (not containing paint) from sawmills, carpentry and other activities related to processing and working with wood. Given that it does not use any glue to hold it together this type of fuel is completely environmentally friendly. In fact the compactness of the pellets over time is guaranteed by a natural substance found in the wood itself: wood coal. In addition to being an environmentally friendly fuel in that it pushes wood residues to the limits pellets also have a technical advantages. While wood has a calorific value of 4.4 kWh/kg. (with 15% humidity after around 18 months of seasoning) the calorific value of pellets is 5 kWh/kg. Pellet density is 650 kg/m^3 and the water content is equal to 8% of its weight. For this reason they do not require seasoning in order to arrive at a sufficiently adequate degree of heat yield.



The pellets used must comply with the characteristics described by the following standards:

- EN PLUS – EN 16961 – 2 class a1 or a2
- Ö-NORM M 7135
- DIN PLUS 51731

The manufacturer always recommended using pellets with a diameter of 6mm-8mm with its products.

Pellet storage

In order to ensure problem-free combustion pellets must be stored in a dry place.

Open the tank lid and load pellets using a scoop.

USER INTERFACE

THE KEYBOARD REMOTE CONTROL

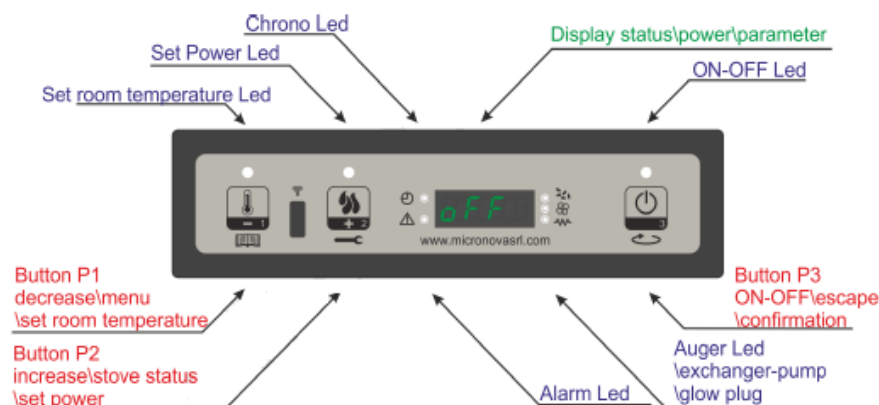

Through the console you can have a dialogue with the control board simply by pressing a few buttons. The display and LED indicators inform the operator of the operating status of the heater. In programming mode, various parameters are displayed, which can be modified by pressing the keys. The unit interfaces with the console by means of a connection that is made according to Micronova standards and is compatible with all Micronova products belonging to the heater range. Both the appearance of the display panel and the silk screen print are customizable by the client.

What are the Buttons?

Button	Description	Mode	Action
1	Decrease temperature	SET TEMPERATURE	Decrease the value of SET room temperature
		PROGRAMMING	Decrease the selected parameter
		SET POWER	Decrease the power value
2	Increase temperature	SET TEMPERATURE	Increase the value of set room temperature
		PROGRAMMING	Increase the selected value
		SET POWER	Increase the power value
3	ON/OFF	ON	Hold for 2 seconds to switch the stove on when in off mode, or off when in on mode.
		PROGRAMMING	It allows you to select the parameters to be programmed

What are the Leds?

LED	The meaning of led ON
SET ROOM	Set room programming
SET POWER	Set power programming
TIMER PROGRAM	Timer program ON
ALARM	Stove in alarm status
AUGER ON	Auger is moving
EXCHANGER-PUMB	Exchanger\pump on
ON\OFF	Working state

OPERATING MODE

Described below are the normal functions of the controller that is ordinarily installed in an air heater, with respect to functions available to users.

- 1- **Starting Stove:** To light the stove hold the P3 button for a few seconds. Once turned on, the display shows “Start” as below, and the ON/OFF LED will flash.

The heater now enters a state of pre-heating, during which the glow plug and the air extraction fan both turn on (this is visible on the glow plug LEDs and shown at below). Any problems during the turning on phase will be shown on the display and the heater’s alarm will sound (phase refer to Alarms).

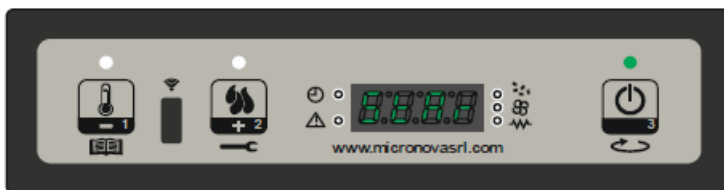

- 2- **Pellet Loading:** After about 1 minute, the pellet loading phase will begin, the display will show “Load Pellet” and the ON/OFF LED will flash intermittently. During the first phase, the feed screw loads the pellets into the brazier for a period (the feed screw LED will come on). The glow plug and its LED remain on. In the second phase, after the period of time stipulated at some seconds, the feed screw (and its LED) will turn off for a period, while the speed of the air extractor will remain the same and the glow plug will still be on as before. (figure at below).

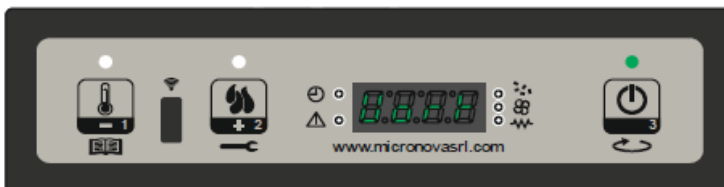

- 3- **Fire On:** After the flue temperature has reached and surpassed the level stated the value, the system will enter the on mode and display “Flame Present” on the display, with the ON/OFF LED flashing. In this phase. (with the feed screw LED on intermittently) and the glow plug (and its LED) will switch off. Any problems during this phase will stop the heater and an error message will show (please refer to Alarms).
- 4- **Working Mode:** After the flue temperature has reached the value the heater will enter the work mode, which is its normal function. The display will show “Work” and the ON/OFF LED will be on. Power can be adjusted by pressing the P2 key and ambient temperature by pressing the P1 key (at below a). If the temperature of the air reaches the threshold the air exchanger fan will switch on (along with its LED).



In this phase, after a period, the heater will clean out the brazier. The display will show “Cleaning brazier”, the feed screw (and its LED) will switch on, and the extractor fan will run at a cleaning speed (at below b). After the period, the heater will return to its work mode



- 5- **Change the set heating power:** During the normal functioning of the heater (“Work” mode), it is possible to change the heat emitted by pressing the P2 key (the “Set Power” LED will turn on). To increase the heat, press P2 again, and to decrease press P1. The level of heat selected is shown on the display. To exit this setting, wait 5 seconds without pressing any keys, or press P3.
- 6- **Adjusting the room temperature setting:** To adjust the room temperature setting, simply press the P1 button. The display shows the room temperature set (SET Temperature). Pressing P1 (to reduce) and P2 (to increase) will change this number. After about 5 seconds, the number entered is memorized by the heater and the display returns to normal. Alternatively, to exit you can press P3.

- 7- **Room temperature reaches the set temperature:** When the ambient temperature has reached the level set, the power of the heater automatically reduces to the minimum level. At this point, the display will show the message “Modulate”. If the room temperature drops below the set temperature, the heater will return to working mode at the power previously set



- 8- **Stand-by:** If enabled in the menu, the stand-by function allows you to turn off the heater once the following conditions are satisfied. If, for period of time given value, the ambient temperature is higher than the set temperature by more than value, this function will be enabled. The display will show “Go-standby” followed by the minutes remaining (at below)

At the end of the time given period the display will show “Wait Cooling”. In this state, the feed screw (and its LED) will turn off, the air exchanger will turn off once it reaches the threshold value, and the ON/OFF LED will flash.

When the temperature of the air reaches the threshold given value, the heater enters stand-by mode and the display will show “Stop eco temp good”. The feed screw (and its LED), the air exchanger fan (and its LED) and the ventilator will all turn off.

If the room temperature drops to below the set temperature by more than the threshold value, the heater will turn back on.



- 9- **Switching off the stove:** To turn off the heater, press and hold the P3 key. The display will show “Cleaning final”. The feed screw motor (and its LED) will turn off, the ventilator will be at the off speed and the ON/OFF LED will flash. The air exchanger fan (and its LED) will remain on until the temperature of the air drops below the level stated at value. After a period, if the temperature of the air is below the threshold value, the heater will turn off and the display will show “Off”. (at below)



MENU

To access the menu, press and hold P1. The menu is subdivided into various levels and items that allow access to the settings and programming of the system.

<i>Level 1</i>	<i>Level 2</i>	<i>Level 3</i>	<i>Value</i>
M1 - set clock			
	01 – Day week		M-T-W-T-F-S-S
	02 – Hour		0-23
	03 – Minute		0-59
	04 – Day		1-31
	05 – Month		1-12
	06 - Year		0-99
M2 – Set chrono			
	M-2-1 Chrono enable		
		01 Chrono enable	On/Off
	M-2-2 Chrono day		
		01 Chrono day	On/Off
		02 - Start 1 day	Off – 0 – 23:50
		03 - Stop 1 day	Off – 0 – 23:50
		04 - Start 2 day	Off – 0 – 23:50
		05 - Stop 2 day	Off – 0 – 23:50
	M-2-3 Program week		
		01 - Weekly chrono	On/Off
		02 - Start prog 1	Off – 0 – 23:50
		03 - Stop prog 1	Off – 0 – 23:50
		04 - Monday prog 1	On/Off
		05 - Tuesday prog 1	On/Off
		06 - Wednesday prog 1	On/Off
		07 – Thursday pog 1	On/Off
		08 - Friday prog 1	On/Off
		09 - Saturdar prog 1	On/Off
		10 - Sunday prog 1	On/Off

Level 1	Level 2	Level 3	Value
		11 - Start prog 2	Off – 0 – 23:50
		12 - Stop prog 2	Off – 0 – 23:50
		13 - Monday prog 2	On/Off
		14 - Tuesday prog 2	On/Off
		15 - Wednesday prog 2	On/Off
		16 – Thursday pog 2	On/Off
		17 - Friday prog 2	On/Off
		18 - Saturdar prog 2	On/Off
		19 - Sunday prog 2	On/Off
		20 - Start prog 3	Off – 0 – 23:50
		21 - Stop prog 3	Off – 0 – 23:50
		22 - Monday prog 3	On/Off
		23 - Tuesday prog 3	On/Off
		24 - Wednesday prog 3	On/Off
		25 – Thursday pog 3	On/Off
		26 - Friday prog 3	On/Off
		27 - Saturdar prog 3	On/Off
		28 - Sunday prog 3	On/Off
		29 - Start prog 4	Off – 0 – 23:50
		30 - Stop prog 4	Off – 0 – 23:50
		31 - Monday prog 4	On/Off
		32 - Tuesday prog 4	On/Off
		33 - Wednesday prog 4	On/Off
		34 – Thursday pog 4	On/Off
		35 - Friday prog 4	On/Off
		36 - Saturdar prog 4	On/Off
		37 - Sunday prog 4	On/Off
	M-2-4Programweeknd		
		01 – Chrono weekend	
		02 - Start 1 weekend	
		03 - Stop 1 weekend	
		04 - Start 2 weekend	
		05 - Stop 2 weekend	
	M-2-5 Escape		set
M3-Set Language			
	01- Italiano		Set
	02- English		Set
	03- Francais		Set

<i>Level 1</i>	<i>Level 2</i>	<i>Level 3</i>	<i>Value</i>
	03- Deutsch		Set
M4 – Stand-by			
	01- Stand-by		On/Off
M5 – Buzzer			
	01- Buzzer Mode		On/Off
M6 – Initial Load			
	01- Initial Load		90”
M7 –Stove state			
	01- Stove state		
		01 – Auger state	info
		02 – T minutes	Info
		03 – Thermostat state	Info
		04 – Flue state	Info
		05 – Smoke fan (rpm)	Info
M8 –Technical st.			
	01- Access key		set
M9 –Escape			
	01- Escape		set

- 1- **Set Clock (M1):** Sets the current time and date. The circuit board comes equipped with a lithium battery that allows the internal clock to have an autonomy of over 3/5 years. To access the general programming menu, press P1 for 2 seconds. Pressing P1 (to go down) or P2 (to go up) will select the M1 item, and the display will show “M1 set time”. Choose the desired day and press P3 (figure at below). Then set the hour, the minute, day, month, and year by pressing P1 to go down and P2 to go up. To confirm, press P3.



2- Set timer program (M2)

***Enable chrono (M2-2):** The menu shown on the “M2 set chrono” display allows you to enable or disable all of the functions of the chronothermostat in one go. To enable them, press P3 and then either P1 or P2 for On or Off respectively. Confirm by pressing P3.

***Program day (M2-2):** Select the menu “M2-2 program day” and press P3 to see and enable or disable the various parameters for programming the daily chrono settings. It is possible to set two functioning slots, the first with START1 Day and STOP1 Day and the second with START2 Day and STOP2 Day. These slots can be defined according to the timings set out in the table below, where the OFF setting tells the clock to ignore the command. To modify, use P1 (to go down) and P2 (to go up). Confirm with P3.

<i>Program Day</i>			
Menu level	Selection	Meaning	Possible values
M2-2-01	PROGRAM DAY	Enable chrono day	ON/OFF
M2-2-02	START 1 Day	Wake time	OFF -0-23:50
M2-2-03	STOP 1 Day	Off-time	OFF-0-23:50
M2-2-04	START 2 Day	Wake time	OFF-0-23:50
M2-2-05	STOP 2 Day	Off – time	OFF-0-23:50

***Program week (M2-3):** The “M2-3 Program Week” menu allows you to enable or disable and set the weekly chrono thermo stat. The weekly function has 4 independent programs. Additionally, pressing OFF on the timetable will tell the system clock to ignore the corresponding command. The following tables present the weekly program functions. To get to the next function and select it, press P3. You can exit the menu by pressing and holding P3.

<i>Enable Program Week</i>			
Menu level	Selection	Meaning	Possible values
M2-3-01	PROGRAM WEEK	Enable program week	ON/OFF

<i>Program 1</i>			
Menu level	Selection	Meaning	Possible values
M2-3-02	START PROG 1	Wake time	OFF -0-23:50
M2-3-03	STOP PROG 1	Off time	OFF-0-23:50
M2-3-04	MONDAY PROG1	Reference day	ON/OFF
M2-3-05	TUESDAY PROG1		ON/OFF
M2-3-06	WEDNESDAY PROG1		ON/OFF
M2-3-07	THURSDAY PROG1		ON/OFF
M2-3-08	FRIDAY PROG1		ON/OFF
M2-3-09	SATURDAY PROG1		ON/OFF
M2-3-10	SUNDAY PROG1		ON/OFF

Program 2			
Menu level	Selection	Meaning	Possible values
M2-3-11	START PROG 2	Wake time	OFF -0-23:50
M2-3-12	STOP PROG 2	Off time	OFF-0-23:50
M2-3-13	MONDAY PROG 2	Reference day	ON/OFF
M2-3-14	TUESDAY PROG 2		ON/OFF
M2-3-15	WEDNESDAY PROG 2		ON/OFF
M2-3-16	THURSDAY PROG 2		ON/OFF
M2-3-17	FRIDAY PROG 2		ON/OFF
M2-3-18	SATURDAY PROG 2		ON/OFF
M2-3-19	SUNDAY PROG 2		ON/OFF

Program 3			
Menu level	Selection	Meaning	Possible values
M2-3-20	START PROG 3	Wake time	OFF -0-23:50
M2-3-21	STOP PROG 3	Off time	OFF-0-23:50
M2-3-22	MONDAY PROG 3	Reference day	ON/OFF
M2-3-23	TUESDAY PROG 3		ON/OFF
M2-3-24	WEDNESDAY PROG 3		ON/OFF
M2-3-25	THURSDAY PROG 3		ON/OFF
M2-3-26	FRIDAY PROG 3		ON/OFF
M2-3-27	SATURDAY PROG 3		ON/OFF
M2-3-28	SUNDAY PROG 3		ON/OFF

Program 4			
Menu level	Selection	Meaning	Possible values
M2-3-29	START PROG 4	Wake time	OFF -0-23:50
M2-3-30	STOP PROG 4	Off time	OFF-0-23:50
M2-3-31	MONDAY PROG 4	Reference day	ON/OFF
M2-3-32	TUESDAY PROG 4		ON/OFF
M2-3-33	WEDNESDAY PROG 4		ON/OFF
M2-3-34	THURSDAY PROG 4		ON/OFF
M2-3-35	FRIDAY PROG 4		ON/OFF
M2-3-36	SATURDAY PROG 4		ON/OFF
M2-3-37	SUNDAY PROG 4		ON/OFF

***Program weekend (M2-4):** Allows you to enable/disable and set the chronothermostat functions on the weekend (day6 and day7, or Saturday and Sunday). To enable, press P3 on the “chrono weekend” item and select “on” by pressing P1 /to go down) or P2 (to go up). Selecting the times under START 1 WEEKEND and STOP 1 WEEKEND will set the times that the heater will function on SATURDAY, while START 2 WEEKEND and STOP 2 WEEKEND will set the operating times fur SUNDAY.

<i>Program Weekend</i>			
Menu level	Selection	Meaning	Possible values
M2-4-01	PROGRAM weekend	Enable chrono weekend	ON/OFF
M2-4-02	START 1 weekend	Wake time	OFF -0-23:50
M2-4-03	STOP 1 weekend	Off-time	OFF-0-23:50
M2-4-04	START 2 weekend	Wake time	OFF-0-23:50
M2-4-05	STOP 2 weekend	Off – time	OFF-0-23:50

- 3- Language Selection (M3):** Allows you to set the language from those available. (figure at below). To move to the next language, press P2 (to go up) and to go back press P1. To confirm, press P3.



- 4- Stand By (M4):** Allows you to enable or disable Standby mode (figure at below). Once you have selected the M4 menu using the P3 key, press P1 (to go down) or P2 (to go up) to switch between ON and OFF and vice versa. For more information on the standby function, please refer to the paragraph on standby.



- 5- **Alarm Mode (M5):** Allows you to enable or disable the buzzer on the controller when the alarm goes off. To enable or disable, press P1 or P2 respectively. To confirm, press P3.
- 6- **First Charge (M6):** This function is only available when the heater is OFF. It allows the feed screw to load at the first start of the heater, when the pellet tank is empty. After selecting the M6 menu, the display will show “Press again”. Press P2 (to increase). The ventilator will turn on at maximum speed, the feed screw (and its LED) will turn on and remain on until the end of the time shown on the display or until you press the P3 key .
- 7- **Stove Status (M7):** In menu M7, the display will show the status of several variables during the operation of the heater in work mode. The table below shows an example of the display and the meaning of these numbers.

Visualized status	Meaning
3,1”	Feed screw pellet
52’	Time out
Toff	Thermostat
106°	Flue temperature
1490	Smoke extraction

- 8- **Technical Settings (M8):** This item in the menu is accessible only to the technician who installed the heater.
- 9- **Excape (M9):** Selecting this item by pressing P3 (figure at below), you can exit the menu and return to the previous position



Electrical Layout

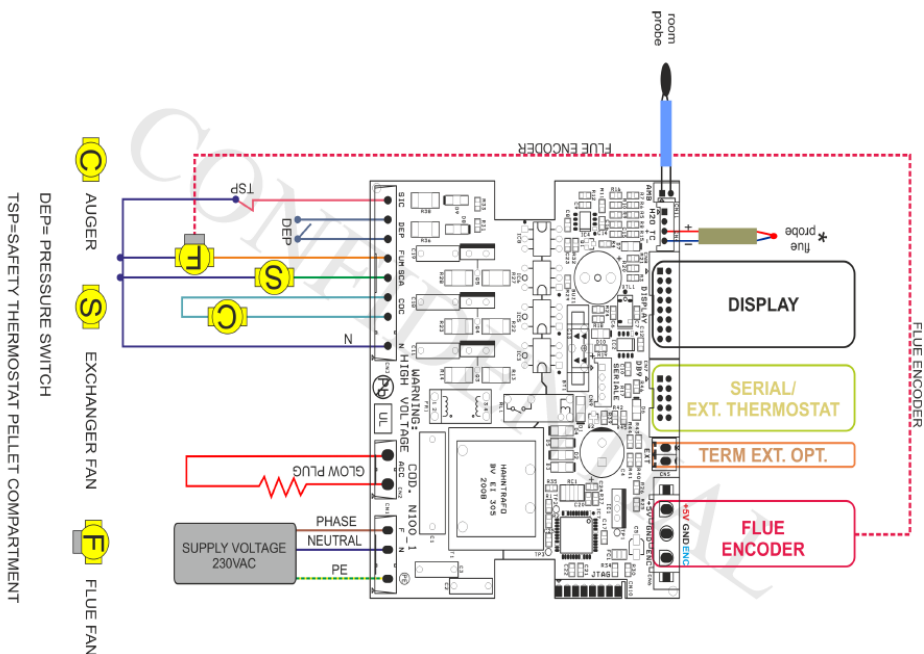

MAINTENANCE

Maintenance warnings

Inspection and maintenance operations must be carried out by specialized technicians who are aware of the directions reported in this manual.

Before carrying out any work, make sure that:

- The power cable's plug has been pulled out, as the generator might have been programmed to turn on.
- All the generator parts are cold.
- The ashes are completely cold.
- Periodically inspect the T-shaped fitting on the smoke pipe located on the outlet of the generator by removing the hermetic container, remove any ash and carefully place back the plug with the gasket.



Have the generator, vents and smoke pipe cleaned and checked by specialized personnel every.

DAILY CLEANING TO BE CARRIED OUT BY THE USER

Daily cleaning must be carried out by the generator's user with the utmost care after reading the instructions related to the procedures that need to be carried out later described in this manual.

The images are for illustration purposes.

DAILY



Open the door - Clean the glass with a damp cloth never spray the detergent or any other liquid used for cleaning directly on the ceramic glass

CLEANING THE BURN POT AND COMBUSTION CHAMBER

1. Vacuum the residues in the burn pot
2. Take out the burn pot from the designated compartment;
3. Vacuum the ash from the burn pot's seat and combustion chamber.
4. Use the special poker supplied to clear the holes in the burn pot.
5. Place back the burn pot and push it towards the hearth wall.



6. If there is an ash collector tray, vacuum the ash deposits

Please note: use a suitable vacuum cleaner with a special container to separate the collected ash.

Cleaning the lower sump (if there is one)

Some stove models have an inspection sump behind the ash drawer or underneath the combustion chamber. In this case, just open, remove the clamping screws and vacuum the ash inside.



ROUTINE MAINTENANCE

In order to guarantee proper functioning and safety of the device, the operations indicated below must be performed every season or more often when necessary.

Door, ash drawer and burn pot gaskets

The gaskets ensure the tightness of the generator and its consequent proper operation.

They must be checked periodically: in the event they are worn or damaged they must be replaced immediately. These operations must be carried out by a qualified technician.

Connection to the flue

Vacuum and clean the pipe that leads to the flue yearly or whenever necessary. If there are horizontal sections, the residues must be removed before they can obstruct flue passage.

ALWAYS FOLLOW THE INSTRUCTIONS IN MAXIMUM SAFETY CONDITIONS!

- **With the generator fully cooled down, switched off and disconnected from the mains electricity.**
 - **Failure to clean jeopardy dishes safety!**
 - **To ensure correct operation the generator must undergo routine maintenance by a qualified technician at least once a year.**

ALARMS

If a problem is detected during operation, the machine will intervene and alert you by turning on the alarm LED and making a noise. The following alarms could sound:

Origin of the alarm	Display
Black – out	AL 1 ALAR AL 1BLAC-OUT
Flue gas temperature probe	AL2 ALAR AL2 PROBE EXHAUST
Flue gas over – temperature	AL 3 ALAR AL3 HOT EXHAUST
Flue encoder damaged	AL 4 ALAR AL 4 FAN FAILURE
Ignition failure	AL 5 ALAR AL 5 NO LIGHTIN
Pellet absence	AL 6 ALAR AL 6 NO PELLET
Thermal safety overtemperature	AL 7 ALAR AL 7 SAFETY THERMAL
Depression absence	AL 8 ALAR AL FAILURE DEPRESS-

Every alarm causes the stove to immediately shut down

State of alarm occurs after reaching the Pr11 time, **EXCEPT FOR THE BLACKOUT ALARM**, all alarms are activated after a period of time stated in PR11, and can be reset by pressing and holding the P3 key. For security reasons, each time you reset an alarm, the heater will automatically be turned off. When the alarm is activated, the alarm LED will turn on and, where enabled, the buzzer will buzz intermittently. If the alarm is not reset, the heater will turn itself off and the display will continue to show an alarm message

1- Black out: During the heater's work mode, it might run out of energy. When it restarts, if the blackout period was less than stated in parameter's value, the heater will re-enter the WORK mode; otherwise, the alarm will sound. The display will show the message "Al 1 alar al 1 Blackout" and the heater will turn itself off.

2- Flue gas temperature probe alarm: The alarm will sound if the exhaust probe is faulty. The alarm LED will turn on, the display will show "Al 2 alar al 2 Probe exhaust", and the heater will turn itself off.

3- Flue gas over – temperature alarm: The alarm will sound if the exhaust probe reaches a temperature higher than the fixed, unalterable value given in the parameters. The display will show "Al 3 alar al 3 Hot exhaust" and the heater will turn itself off.

4- Flue encoder alarm: The alarm will sound if the air ventilator is faulty. The display will show "Al 4 alar al 4 Fan failure– damaged".





5- Ignition failure alarm: The alarm will sound when the heater fails to turn on properly, i.e. if within the period of time given in parameter's value, the air temperature does not rise above paramete' value. The alarm will come on and the display will show "Al 5 alar al 5 No lightin-".

6- Pellet absence alarm: In work mode, if the flue temperature drops to below parameter's value, the alarm will sound. The display will show "Al 6 alar al 6 no pellet".

7- Overtemperature safety alarm: The alarm will sound when the general security thermostat reaches a temperature higher than the trigger threshold. The thermostat will intervene and turn off the feed screw, and the controls will indicate a state of alarm, with the alarm LED on and the display showing "Al 7 alar al 7 safety thermal" . The heater will then turn itself off.

8- Depression failure alarm: The alarm will sound when the external pressure switch reaches a pressure reading lower than the trigger threshold. The pressure switch will turn off the feed screw and the controls will indicate a state of alarm (with the alarm LED on), while the display will read "Al 8 alar al 8 failure depress-" . The heater will then turn itself off.

COMBUSTION PHASE OF FLAMES SIMULATING

Combustion phase of flames simulating	
1. PHASE	2. PHASE
After pressing the ON button the device begins to take fuel and the heater is activated	Approximately after 4 – 4,5 minutes the first flame
	
3. PHASE	4. PHASE
Approximately after 5 – 6 minutes the flame begins to grow	Approximately after 7 – 8 minutes it begins to reach the saturation point. Gas of the flue is increasing. The device is to control itself
	
5. PHASE	
Approximately after 8 – 10 minutes the complete combustion stage is reached	
	



hoşseven
ISI VE YALITIM SAN. TİC. AŞ.

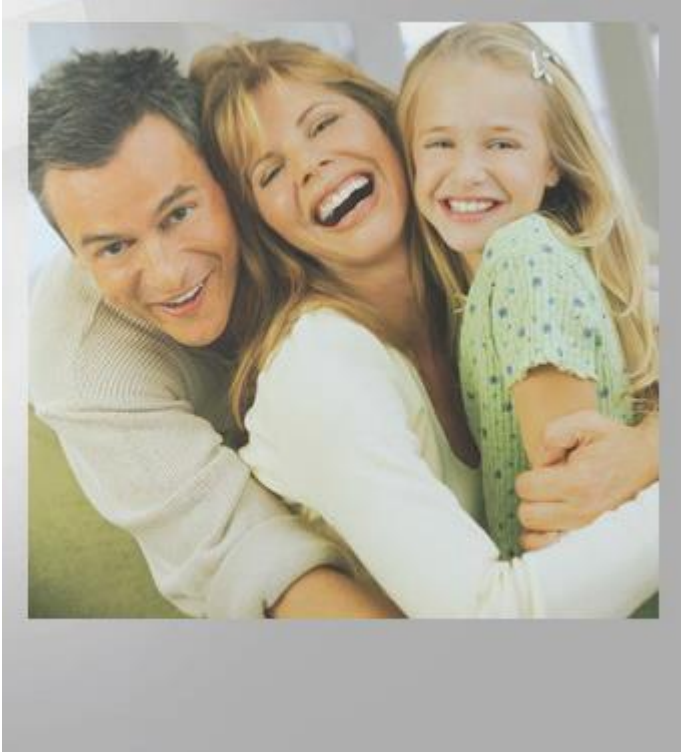

Warm houses, happy smiles

Your happiness is treasure for us

Barakfakih mahallesi 10 cadde No:2 Barakfakih organize sanayi bölgesi Kestel/BURSA/TÜRKİYE

PHN: +90 224 384 11 10 FAX: +90 224 384 11 14 e-mail: hosseven@hosseven.com.tr

www.hosseven.com.tr